

REF  
EAN



**AA18000**  
8427950340215  
Polished finish

## HAND DRYER AVE



**AA18500**  
8427950340246  
Satin finish

### General description

- Totally automatic: it uses an infrared sensor to activate instant drying and stops when it detects no hands.
- Approx. drying time: 10 sec.
- Class II: No earth wire required.
- Line air outlet integrated in the bottom.
- HEPA filter.

### Certifications



### Colour/Finish

**AA18000/AA18500**  
• Polished or satin  
INOX AISI 304 cover

### Technical specifications

VOLTAGE:	220 - 240 V AC
FREQUENCY:	50-60 Hz
MOTOR POWER:	750 W
HEATING POWER:	650 W
TOTAL POWER:	1400 W
MOTOR RPM:	23000
AIR SPEED:	525 km/h
ACOUSTIC PRESSURE:	63.8 dB
AIR TEMPERATURE:	40 °C (at 10 cm distance)
ELECTRIC ISOLATION:	CLASS II
PROTECTION GRADE:	IP23

### Parts and materials

**AA18000/AA18500**  
• Polished or satin  
stainless steel INOX AISI 304 cover.  
• Technical fireproof plastic inner  
parts.

## Product diagram (mm)

**AA18000/AA18500**

Net weight: 4.287 kg

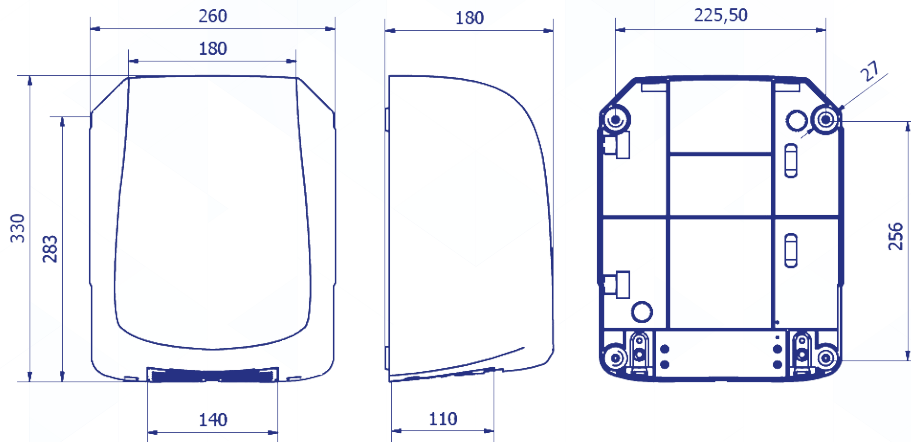

## Dimensions with packaging

<b>AA18000/AA18500</b>			
<b>Height</b>	<b>Width</b>	<b>Depth</b>	<b>Weight</b>
365 mm	328 mm	220 mm	4.946 kg

## Electrical diagram

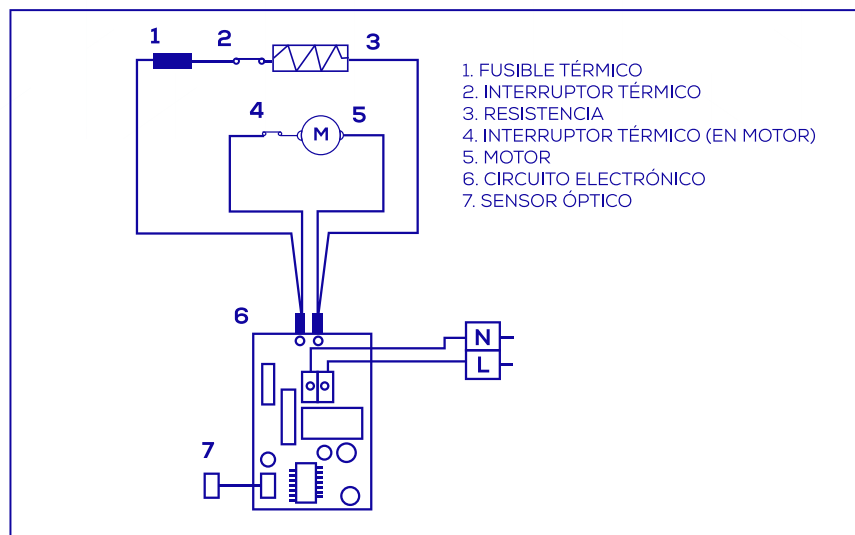

## Package

- Package with one item for all the references.

 Drying time: 10 seconds.

*Approved by: Quality Department*

*Date: 11/01/2022*