



AUTOMATIC FUTURA HAND DRYER



AA16000
8427950304194
Polished finish



AA16500
8427950304460
Satin finish

REF
EAN

General description

- Totally automatic: it uses an infrared sensor to activate instant drying and stops when it detects no hands.
- Class II: no earth wire required.
- Safety system with time limit.

Certifications



Colour/Finish

- AA16000/AA16500**
- Polished and satin
 - INOX AISI 304 cover.
 - Black air outlet grill.

Technical specifications

VOLTAGE:	220 - 240 V AC
FREQUENCY:	50 Hz
MOTOR POWER:	140 W
HEATING POWER:	1820 W
TOTAL POWER:	1960 W
MOTOR RPM:	2800
AIR SPEED:	68 km/h
ACOUSTIC PRESSURE:	58 dB
AIR TEMPERATURE:	55 °C (at 10 cm distance)
PROTECTION GRADE:	IP23
ELECTRIC ISOLATION:	CLASS II

Parts and materials

- AA16000/AA16500**
- Steel INOX AISI 304 cover.
 - ABS and 'VO' polycarbonate inner parts.

Product diagram (mm)

AA16000/AA16500

Net weight: 3.630 k

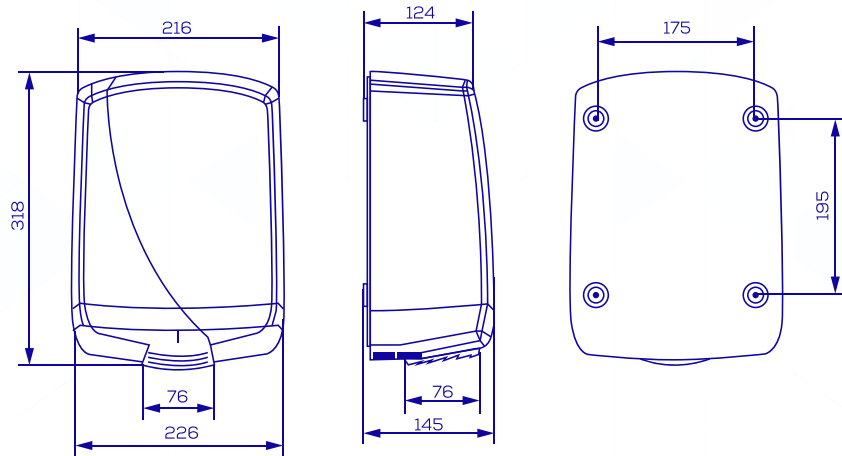

Dimensions with packaging

AA16000/AA16500			
Height	Width	Depth	Weight
380 mm	285 mm	215 mm	4.187 k

Electrical diagram

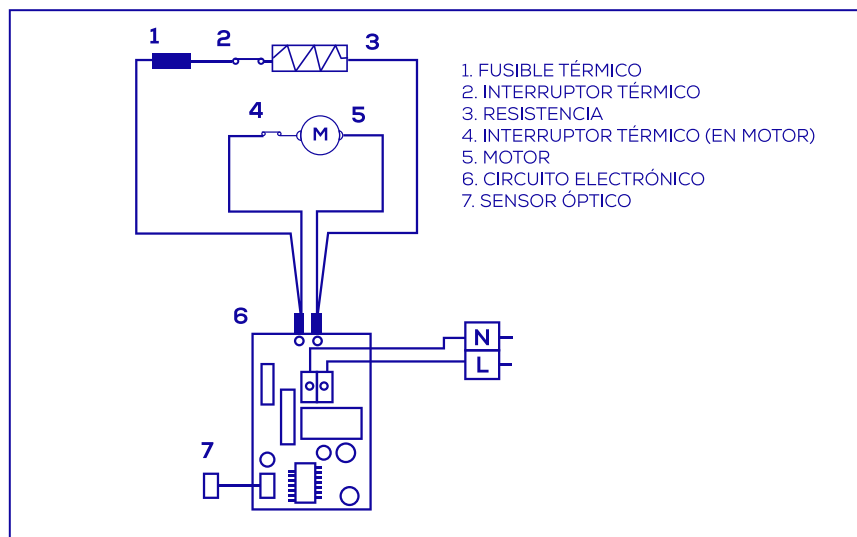

 Mounting: with 4 screws and 4 plugs (included)

Approved by: Quality Department

Date: 21/01/2022